

Stereo microscope Stemi 508
Operating Manual

You have acquired a product made by ZEISS. Please read this operating manual before using your instrument for the first time to make sure that its quality is maintained and you can utilize your instrument reliably for a long time.

Knowledge of this manual is required for operation of the device. Would you therefore please familiarize yourself with the contents of this manual and pay special attention to instructions concerning the safe operation of the device.

We reserve the right to perform modifications in view of technical progress; this operating manual is not subject to revision.

© Unless expressly authorized, forwarding and reproduction of this document as well as utilization and communication of its contents are not permitted. Violations will entail an obligation to pay compensation.

All rights reserved in the event of granting of patents or registration of a utility model.

Issued by: Carl Zeiss Microscopy GmbH
Carl-Zeiss-Promenade 10
D-07745 Jena, Germany

microscopy@zeiss.com
www.zeiss.com/microscopy



Carl Zeiss Microscopy GmbH
Königsallee 9-21
D-37081 Göttingen, Germany

SAP no.: 435064-7044-001

Date of issue (Version 3): 01/28/2015

CONTENTS

	Page
1	INTRODUCTION 7
1.1	General information..... 7
1.2	Notes on instrument safety 8
1.3	Warranty notes..... 11
2	DESCRIPTION 12
2.1	Indication for use..... 12
2.2	Microscope system..... 12
2.3	Interfaces on the stereo microscope Stemi 508 doc (with photo output)..... 13
2.4	System overview 14
2.5	Technical data..... 20
3	INSTALLATION..... 23
3.1	General information..... 23
3.2	Installing the stereo microscope..... 23
3.3	Mounting optional components 25
3.3.1	Mounting reflected-light illuminator 25
3.4	Connecting stereo microscope to the power supply 28
3.5	Switching stereo microscope ON or OFF 28
4	OPERATION 29
4.1	Adjusting the stereo microscope..... 29
4.2	Setting reflected-light illumination 30
4.2.1	Spot illuminator 30
4.2.2	Double spot illuminator 30
4.2.3	Ring illuminator 31
4.2.4	Controller K LED 32
4.3	Transmitted-light illuminators..... 33
4.3.1	Transmitted-light module in stand K EDU..... 33
4.3.2	Transmitted-light unit in stand K LAB..... 34
5	CARE, MAINTENANCE AND SERVICE 35
5.1	Care 35
5.2	Maintenance 36
5.2.1	Replacing the power unit 36
5.2.2	Opening the stand cover plate, stand K EDU..... 37
5.2.3	Opening the stand cover plate, stand K LAB 38
5.2.4	Wearing parts..... 39
5.3	Service..... 39
5.4	Product disposal..... 40

6	APPENDIX.....	41
6.1	List of abbreviations.....	41
6.2	Troubleshooting	42
6.3	List of illustrations.....	43
6.4	Index.....	44

1 INTRODUCTION

1.1 General information

The stereo microscope Stemi 508 has been designed, produced and tested in compliance with the standards DIN EN 61010-1 (IEC 61010-1) and IEC 61010-2-101 "Safety Requirements for Electrical Measuring, Control and Laboratory Equipment".

The device meets the requirements of the EC Directive 98/79/EC Annex 1 regarding ivd products and the EC RoHS Directive 2011/65/EC and carries the **CE** mark.

This operating manual contains information and warnings to be observed by the operator.

The devices must be disposed of in compliance with the WEEE Directive 2012/19/EC.

In this operating manual, the following warning and information symbols are used:



CAUTION

This symbol indicates a possible hazard to the user.



CAUTION

*LED risk group 2 acc. to DIN EN 62471:2009 Optical radiation is emitted.
Do not look into the beam. This may damage your eyes.*



CAUTION: High-energy UV radiation!

Risk of damage to eyes and skin!



CAUTION

Hot surface!



CAUTION

Remove the power plug before any intervention in the instrument!



ATTENTION

This symbol indicates a possible hazard to the instrument or system.



NOTICE

This symbol indicates information which deserves special attention.

1.2 Notes on instrument safety



If it becomes apparent that the safety measures are no longer effective, the device must be taken out of service and secured against being used again unintentionally. Please contact a ZEISS service agency or the Carl Zeiss Microscopy Service to have the instrument repaired.

The Stemi 508 Information regarding instrument safety and installation conditions 435063-6044-008 and the Stemi 508 Short operating instructions 435063-8044-000 as well as the operating instructions regarding the light sources also must be observed.



Do not operate the devices included in the scope of supplies in a potentially explosive atmosphere, in the presence of volatile anaesthetics or flammable solvents such as alcohol, gasoline or similar substances.



The devices may only be operated by instructed persons who have been informed about the possible risks in conjunction with the use of microscopes and the fields of application in question. The microscope is a high-precision device that may be impaired in its performance or even destroyed if handled improperly.



Before commissioning the instrument, make sure that the existing power supply is suitable for the instrument.



Make sure that the mains plug is removed from the socket before the device is opened.



The devices are not equipped with special equipment protecting them from corrosive, potentially infectious, toxic and radioactive or other samples that may be hazardous to health. If you handle such samples, be sure to observe all legal requirements, in particular the relevant national accident prevention regulations.



The LED reflected-light illuminators and the LED transmitted-light illuminators have been classified as belonging to LED risk group 2 acc. to DIN EN 62471:2009. Avoid looking directly into the LED light.



If the device is operated with an external cold light source (high-energy light), never look directly into the fibre optic output of the cold light source. Otherwise, there is a risk of dazzling and blindness.



Never cover the open light guide socket or the fibre optic output. There is a fire hazard!

In all cases avoid covering the open light guide socket or the fibre optic output with your hand or other parts of your body. There is a risk of burns!



Safe disconnection from the power supply is ensured exclusively by removing the mains plug. The switch on the microscope only switches into standby mode.



Do not replace detachable mains cables by inadequately designed mains cables. Only the specified power supply lines may be used.



The microscope and the controller K LED are equipped with a desktop power unit each allowing line voltages in the range from 100 to 240 V $\pm 10\%$, 50 / 60 Hz, without the need for changing the voltage setting on the device.



The desktop power unit meets the requirements of protection class II (with protective insulation). If its casing is damaged, put the power unit out of operation. The microscope may only be operated with the desktop power unit supplied with the instrument.



Changing the lamps on the cold light source is only admissible in accordance with the manufacturer's operating manual. If the appropriate instructions are not complied with, there is a risk of burns and explosion when changing the lamp.



Defective devices should not be disposed of with household waste; dispose of them in compliance with the statutory provisions.



Samples must also be disposed of appropriately in accordance with the applicable statutory provisions and internal work instructions.



The stereo microscope Stemi 508 incl. its original accessories may only be used for the applications described in this operating manual. The manufacturer cannot assume any liability for other applications, including those of individual modules or single components. Changes to and maintenance on this device and on devices which are operated together with the microscope may only be performed by our service or by authorized persons. The manufacturer of the devices does not accept any liability for damage due to unauthorized interventions in the device. Moreover, such interventions invalidate all guarantee / warranty claims.





Dirt and dust may impair the performance of the device. The device must therefore be protected from such influences to the greatest possible extent and covered with the dust cover when not in use. Before covering the device, always make sure that it is definitely switched OFF. Considerable temperature fluctuations, direct exposure to sunlight and vibrations should be avoided.





Blocking or covering ventilation louvers may result in heat accumulation which may damage the device and in extreme cases even cause fire. Always keep ventilation louvers free and do not insert or allow any objects to fall into them. All electrical components and parts must be located at a distance of min. 15 cm from flammable objects and walls.

 If it is intended to operate the Stemi 508 with an external fibre optical cold light source, please refer to the appropriate operating instructions incl. the safety provisions contained in them before commissioning the light source.

 The desktop power unit must not get into contact with moisture.

 For transport over an extended distance, the device must be dismantled partially and transported in its original packaging.

 To transport the device over an extended distance, use the original packaging or the transport case Stemi 305/508.

 To connect the LED illuminators of the Stemi 305 system, six-pin modular connectors are used which are known from telecommunications (type: RJ 12).

Only the LED illuminators pertaining to the Stemi 305 may be connected to the RJ 12 sockets in the microscope body and in the stands of the Stemi 305. Only the connection cables supplied with the device may be used.

The use of commercially available cables with RJ 12 connectors or the connection of fax units, modems or other telecommunication equipment to the RJ 12 sockets of the Stemi 305 is prohibited.

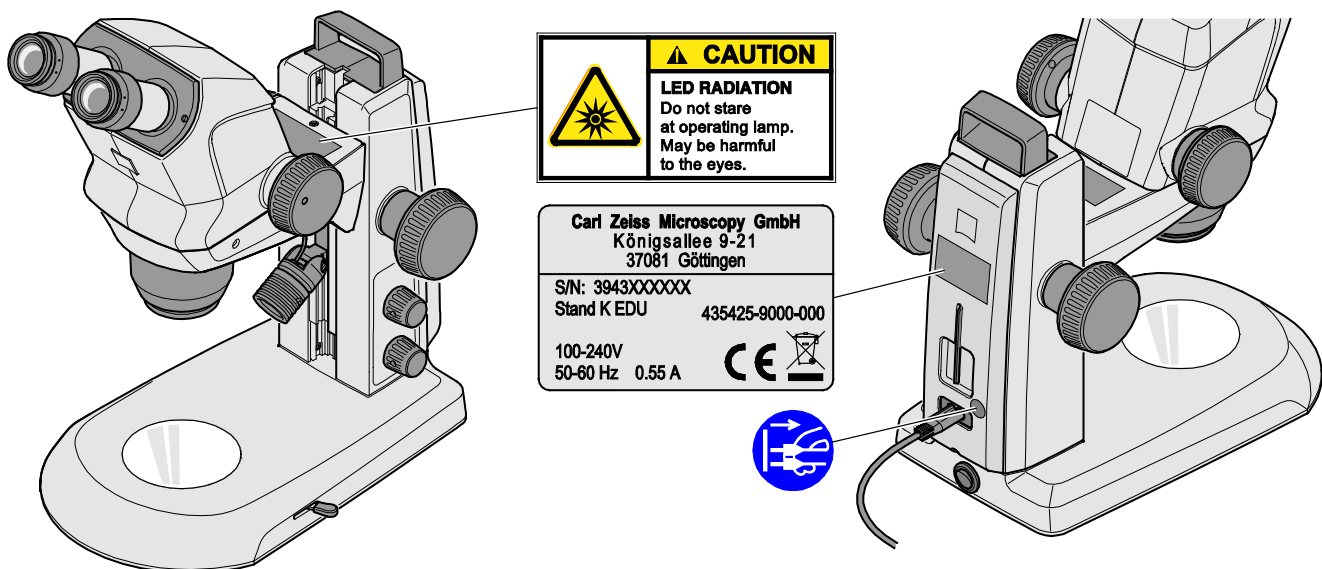
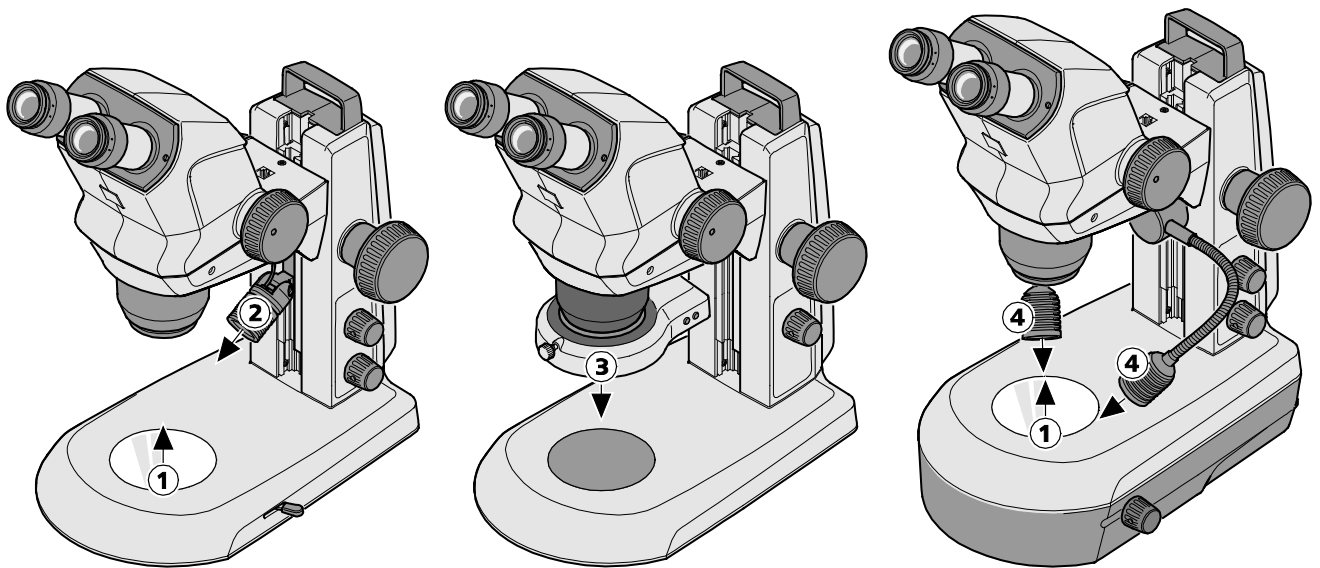

Fig. 1 Warning and information labels on the device



- 1 LED aperture, transmitted-light illuminators
- 2 LED aperture, spot illuminator K LED
- 3 LED aperture, ring illuminator K LED, segmentable
- 4 LED aperture, double spot illuminator K LED

Fig. 2 Apertures for LED radiation

1.3 Warranty notes

The manufacturer guarantees that the device is free from material or manufacturing defects when delivered. Any defects which may have occurred must be reported to us immediately and steps be taken to minimize damage. If notified of such a defect, the device manufacturer is obligated to rectify it at his discretion, either by repairing the instrument or by delivering an intact replacement. No guarantee is provided for defects caused by natural wear (wearing parts in particular) and improper use.

The instrument manufacturer shall not be liable for damage caused by faulty operation, negligence or any other tampering with the device, particularly the removal or replacement of instrument components, or the use of accessories from other manufacturers. Such actions will render all warranty claims invalid.

No maintenance or repair work may be performed on the microscopes which exceed the activities specified in this operating manual. Repair may only be performed by ZEISS Service or by persons specifically authorized by it. Should any malfunctions occur on the device, please first contact the Carl Zeiss Microscopy Service or, abroad, the ZEISS representative in your area.

2 DESCRIPTION

2.1 Indication for use

The stereo microscopes Stemi 508 are microscopes for magnifying spatial observation of small objects. They have been designed and manufactured for use in biological and medical laboratories, in industrial manufacture and quality assurance. They are, moreover, used for training purposes in schools, universities and natural science institutes.

Stemi 508 is envisaged for applications in biology and in medicine for the analysis of blood and/or tissue samples from the human body. Applications in the field of diagnostic medicine are explicitly excluded, except for the field of medical research.

2.2 Microscope system

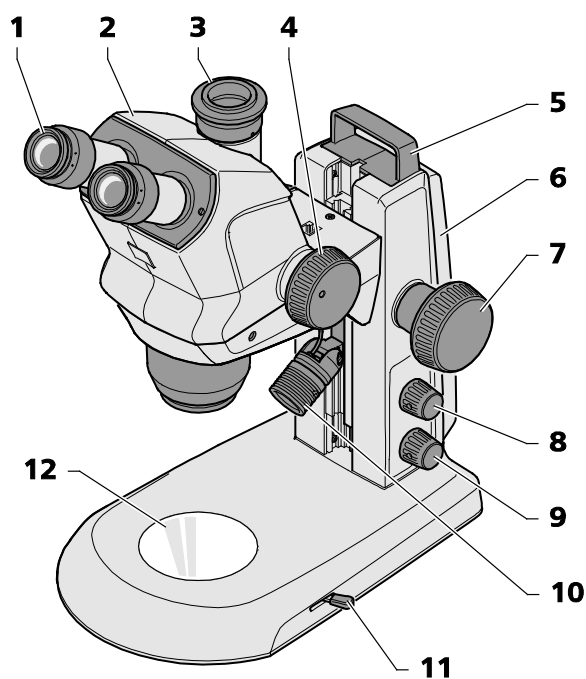

- | | | | |
|---|--|----|---|
| 1 | Eyepiece in eyepiece tube (eyepiece 10x/23) | 8 | Rotary/push-button for switching ON and OFF the reflected-light illumination and for adjusting the illumination intensity |
| 2 | Microscope body (trinocular) | 9 | Rotary/push-button for switching ON and OFF the transmitted-light illumination and for adjusting the illumination intensity |
| 3 | Interface 60N with camera adapter for cameras with C-mount connector | 10 | Reflected-light illumination (spot illuminator K LED) |
| 4 | Zoom button to adjust the magnification | 11 | Lever for adjusting the transmitted-light illuminator – bright field or dark field on the stand K EDU |
| 5 | Handle | 12 | Insert plate for placing the specimen |
| 6 | Stand (model K EDU) | | |
| 7 | Focusing drive to focus the specimen | | |

Fig. 3 Microscope system Stemi 508

 The illustrated microscope equipment shows an example and may differ from the ones actually existing!

2.3 Interfaces on the stereo microscope Stemi 508 doc (with photo output)

- 1 Optional mount for eyepiece plates
Ø 26 mm
- 2 Eyepiece tube Ø 30 mm to replace the eyepieces
- 3 Exchangeable camera adapter 0.5x with interface 60N and C-mount connector for cameras up to 2/3"
- 4 Internal thread M50x0.75 to accommodate the front optics
- 5 Internal thread M49x0.75 to accommodate optical filters and analyzer for pol.
- 6 Mount Ø 53 mm holding ring A53 for adaptation of ring illuminators with mount Ø 66 mm
- 7 Mount Ø 76 mm for microscope body
- 8 Mount Ø 84 mm for tables, insert plates
- 9 Guide for mounting secondary illumination
- 10 M8 thread to mount holding frame (only stand K)

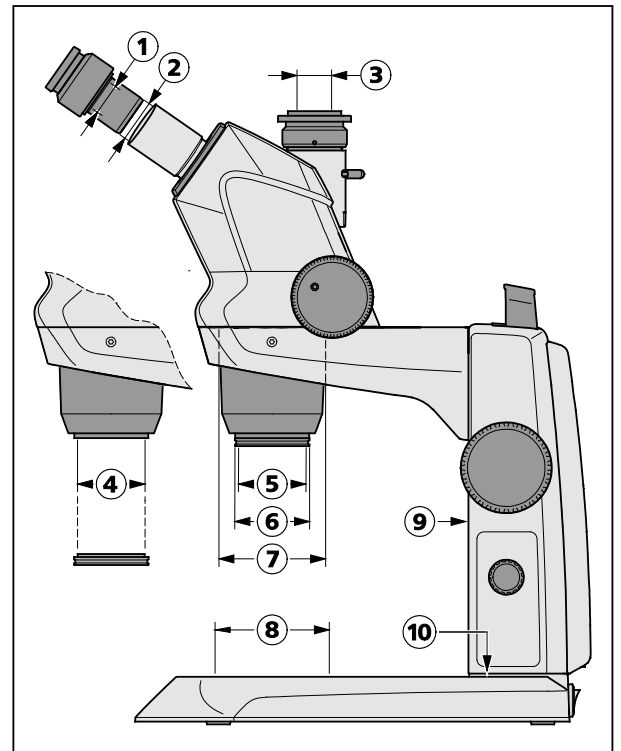

Fig. 4 Interfaces on the Stemi 508 with stand K (schematic diagram)

Thanks to the interface Ø 76 mm, the Stemi 508 can also be used in conjunction with other stands of the modular kit of the Stereo system – and other ZEISS stereo microscopes such as e.g. the Stemi 305, may also be inserted in the stand K LED.

Front optics for Stemi 508

- External thread M50x0.75 for fastening in the zoom body Stemi 508
- Internal thread M49x0.75 to accommodate optical filters and analyzer for pol.
- Before screw-fastening the front optics 5 in the microscope body Stemi 508 remove the dust protection glass.

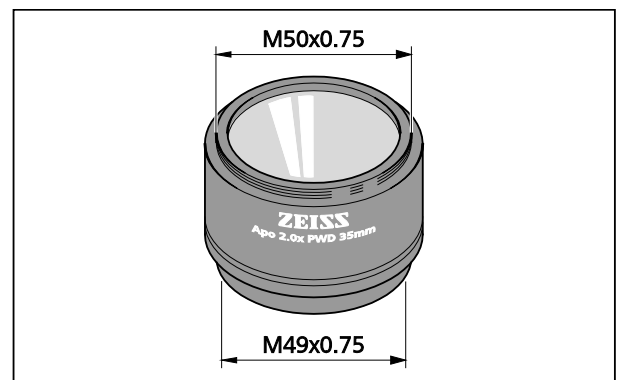
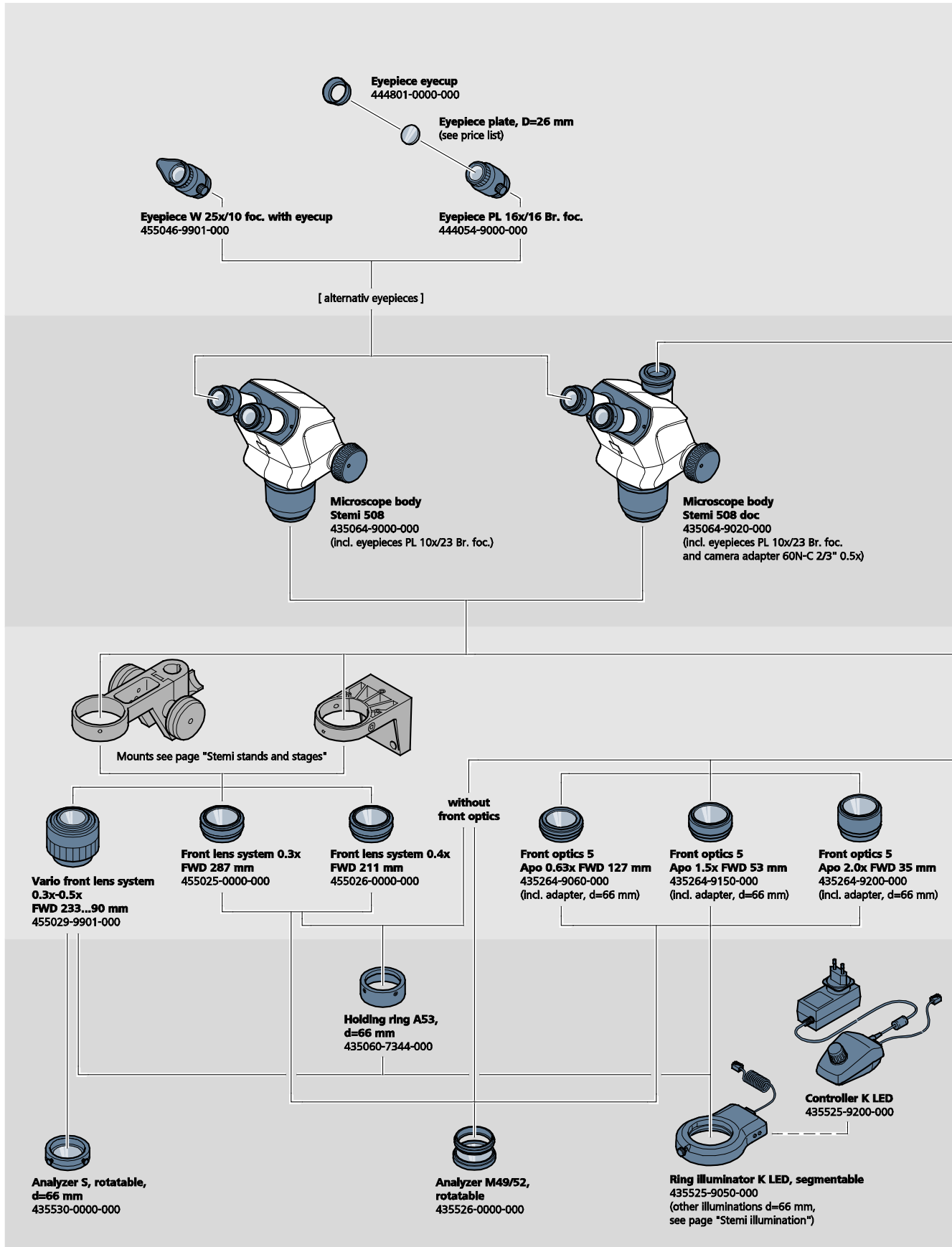
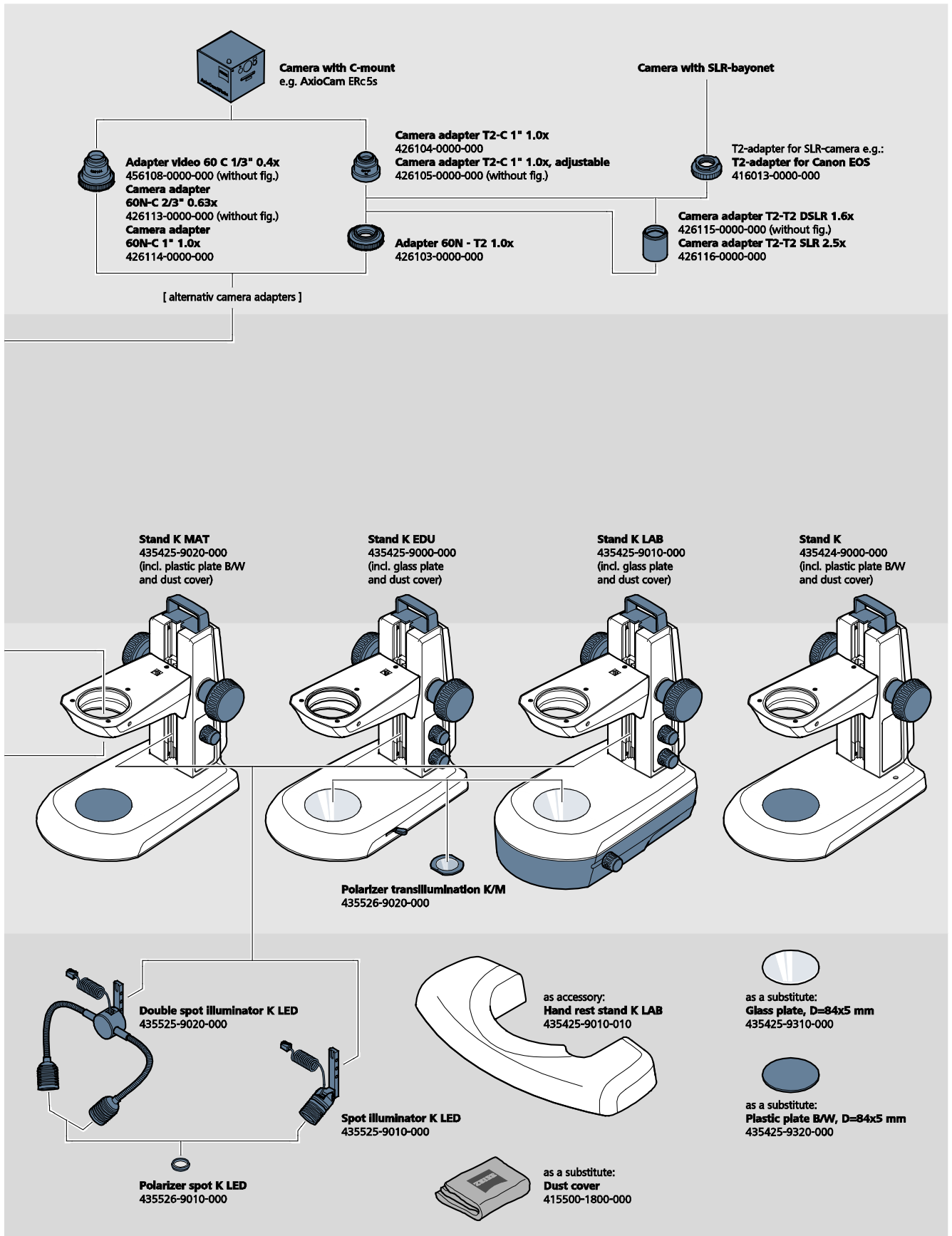
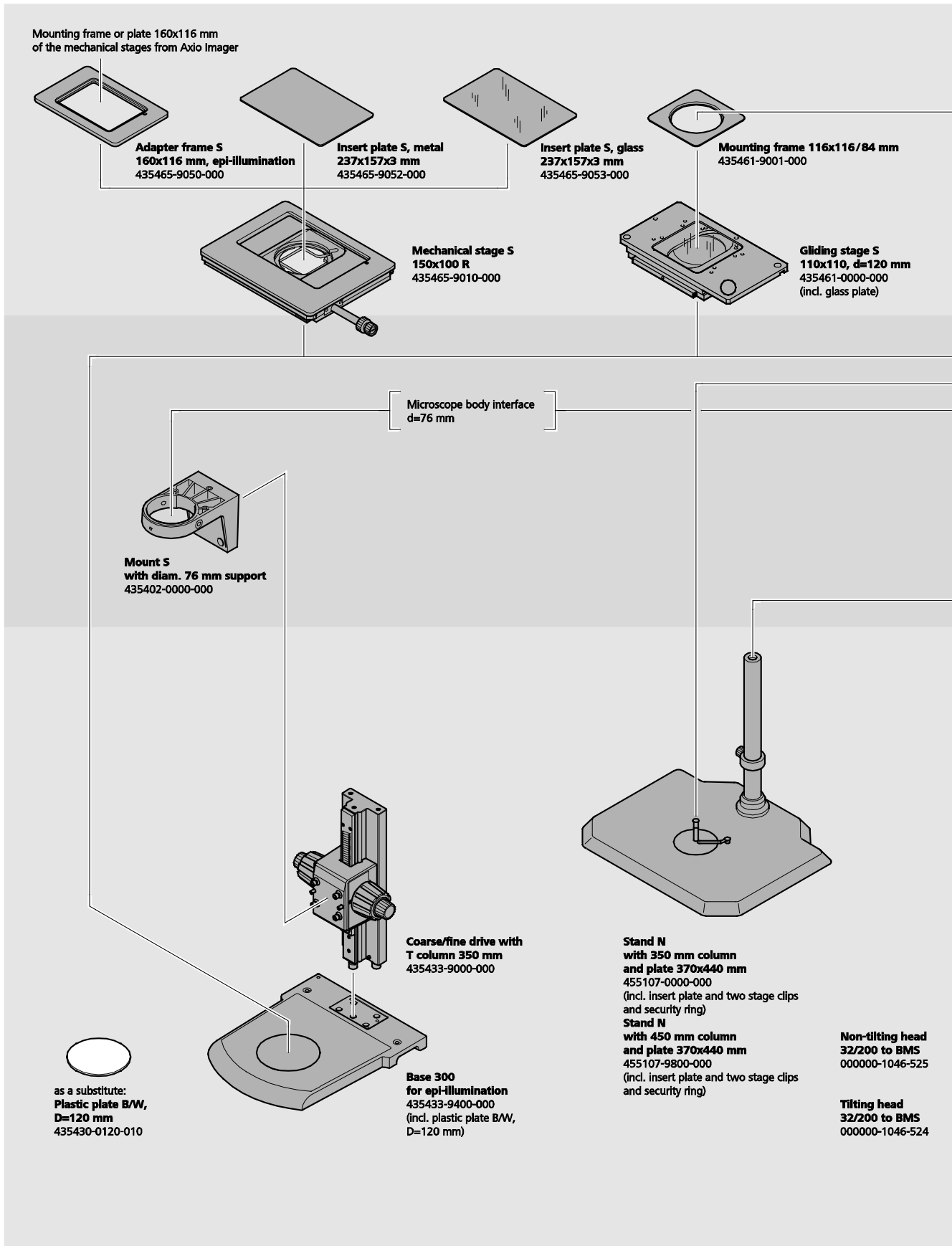

Fig. 5 Front optics, Stemi 508 (example)

2.4 System overview







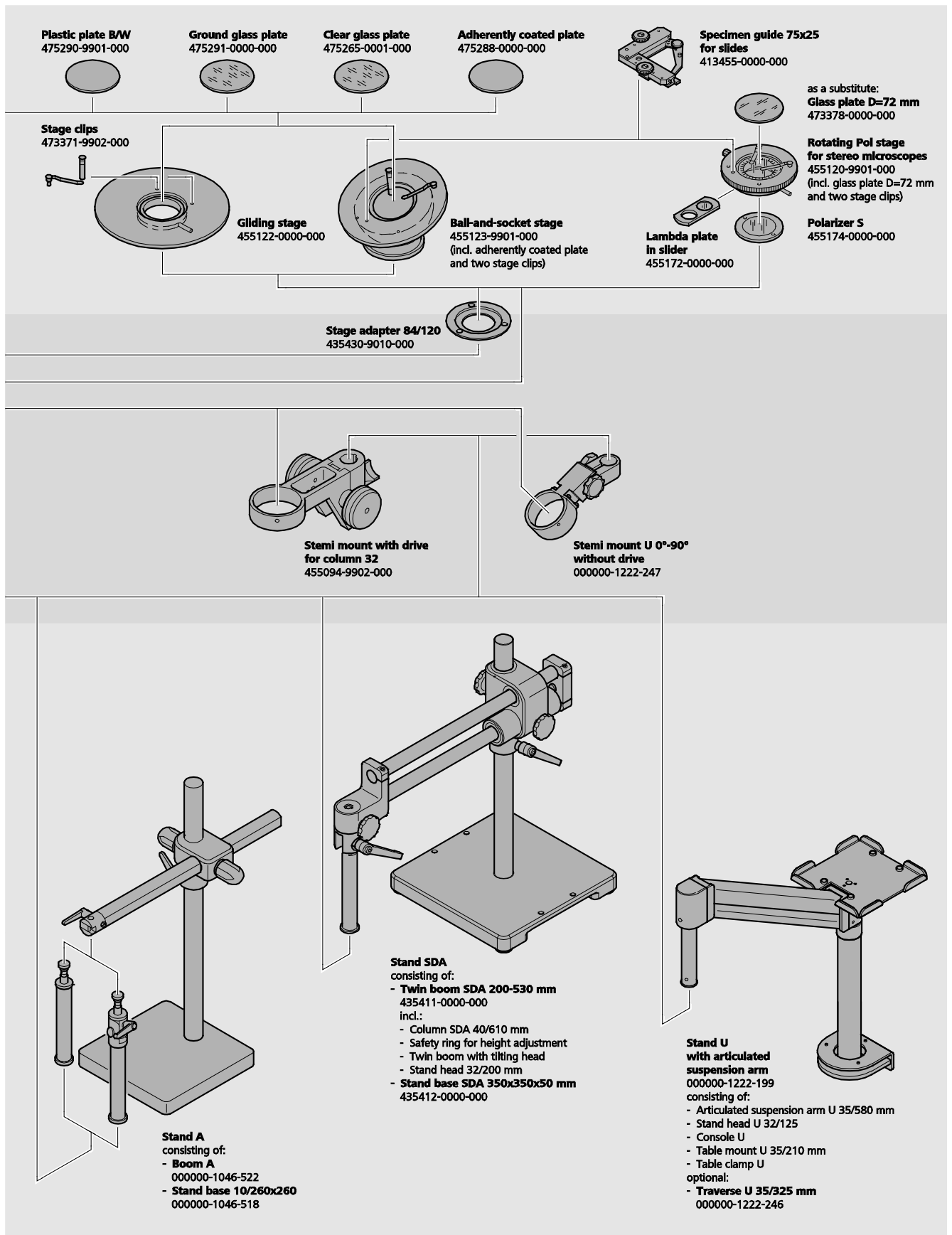

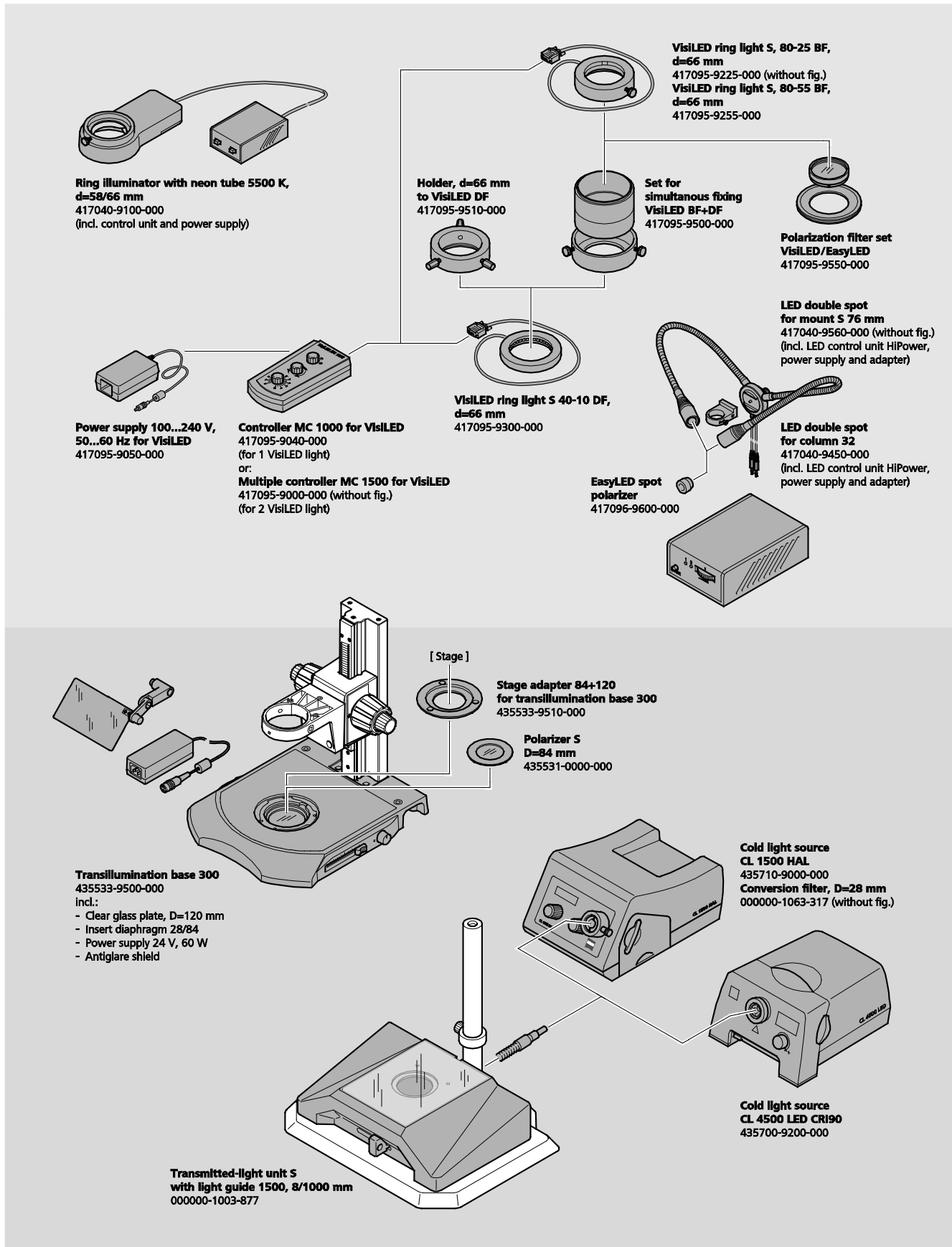

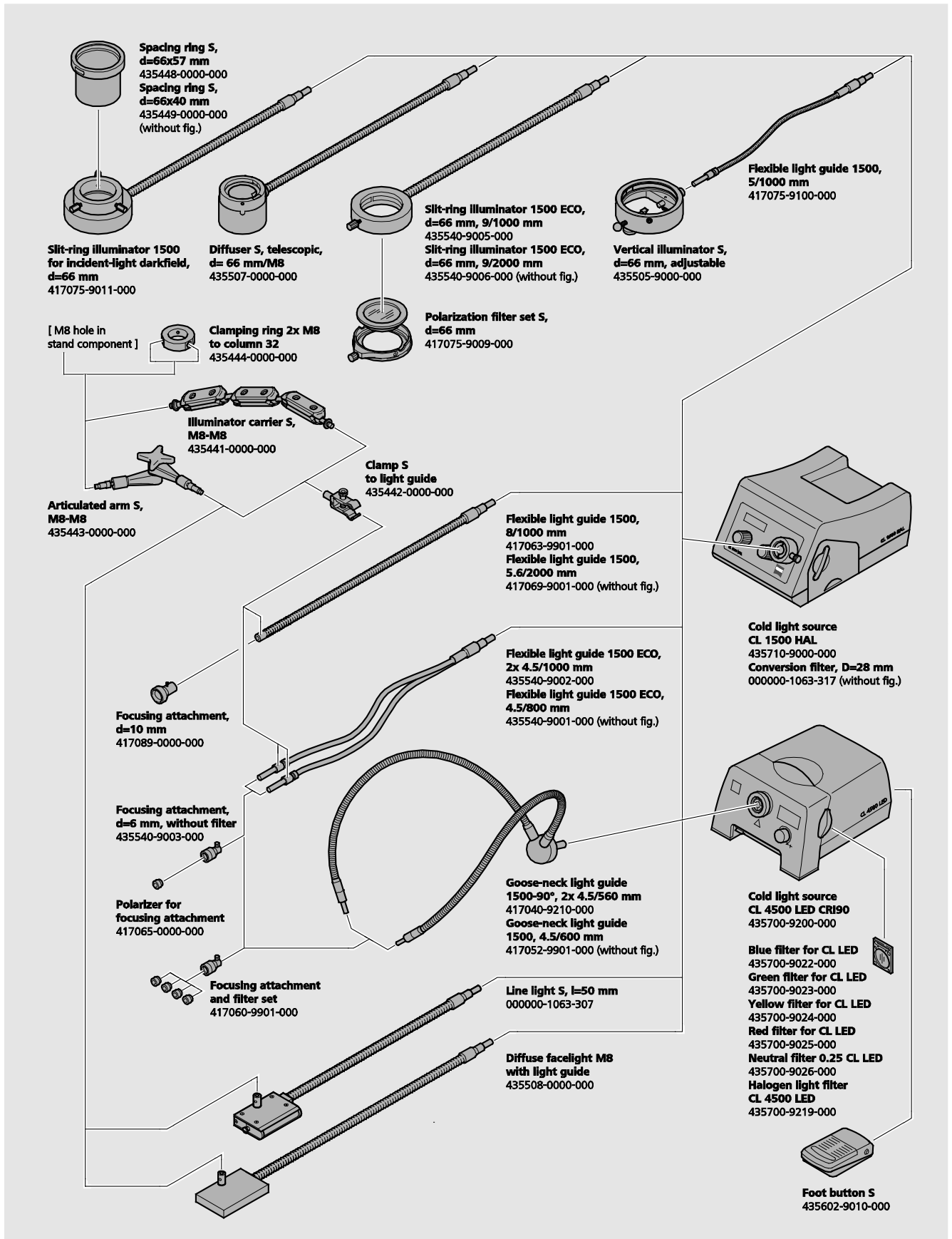

2.5 Technical data

Microscope system Stemi 508 EDU

Dimensions

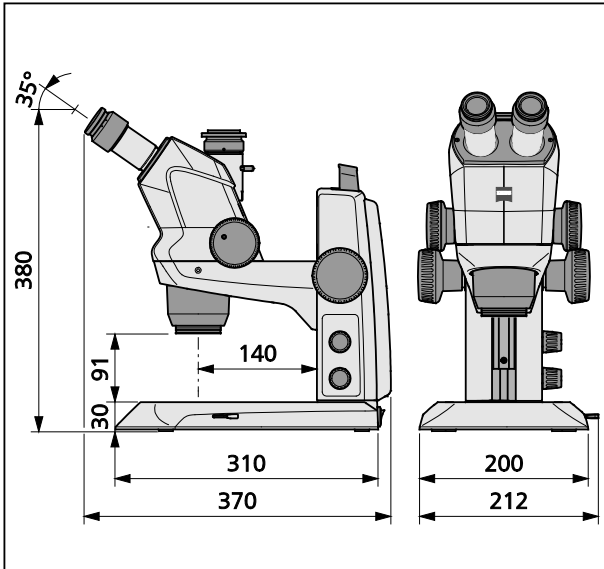

Weight

Stemi 508 in stand K EDU.....4.6 kg

Microscope system Stemi 508 LAB

Dimensions

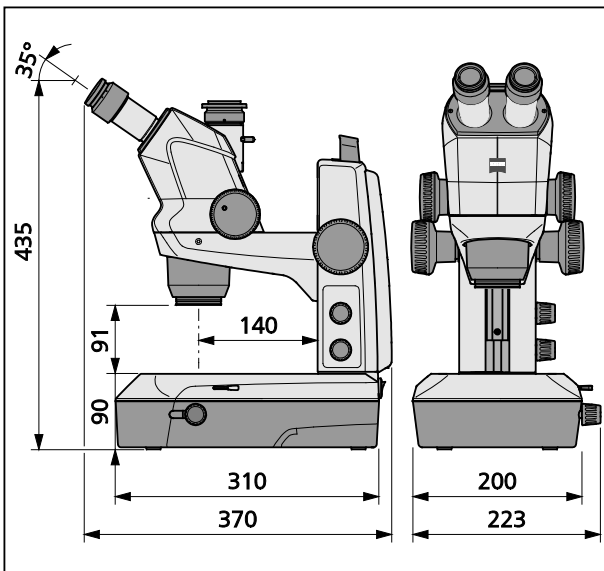

Weight

Stemi 508 in stand K LAB6.2 kg

Ambient conditions

Storage (in packaging)

Admissible ambient temperature..... +10 to +40 °C
Admissible relative humidity..... max. 75 % at +35 °C (non-condensing)

Transport (in packaging)

Admissible ambient temperature..... -40 to +70 °C

Operation

Admissible ambient temperature..... +10 to +40 °C
Admissible relative humidity max. 75 %
Atmospheric pressure800 hPa to 1060 hPa
Pollution degree 2
Field of applicationclosed rooms
Height of field of application..... max. 2000 m

Operating data – desktop power units, microscope and controller K LED

Safety ClassII
Type of enclosureIP 20
Electrical safety..... acc. to DIN EN 61010-1 (IEC 61010-1)
taking CSA and UL regulations into account
Pollution degree 2
Overvoltage category 2
Line voltage..... 100 to 240 V ±10 %
Due to the fact that the instrument features a multi-voltage power supply unit, change-over of the
device voltage not required!
Line frequency..... 50 Hz – 60 Hz
Power consumption: Desktop power unit with connected microscope.....max. 40 VA
Output desktop power unit for microscope
and for Controller K LED 12 V DC, max. 2 A
Input desktop power unit for microscope
and for Controller K LED 100-240 V, 50-60 Hz, max. 0.55 A

Optical risk group classification acc. to DIN EN 62471:2009

Overall device.....	LED risk group 2 acc. to DIN EN 62471:2009
Integrated vertical illumination.....	LED risk group 2 acc. to DIN EN 62471:2009
Spot illuminator K LED (reflected illumination)	LED risk group 2 acc. to DIN EN 62471:2009
Double spot illuminator K LED (reflected illumination).....	LED risk group 2 acc. to DIN EN 62471:2009
Transmitted-light unit in stand K LAB	LED risk group 2 acc. to DIN EN 62471:2009
Transmitted-light unit in stand K EDU	LED risk group 2 acc. to DIN EN 62471:2009
LED reflected illumination, peak at 460 nm,	LED risk group 2 acc. to DIN EN 62471:2009
LED transmitted illumination, peak at 465 nm,	LED risk group 2 acc. to DIN EN 62471:2009

3 INSTALLATION

3.1 General information

 Before installing and commissioning the device, make sure to read the **Notes on Instrument Safety** carefully (see Section 1.2, page 8).

The Stemi 508 with the necessary tools and optional equipment is delivered in several standard packages.

- Take all units out of the packaging and check them for completeness according to the delivery note.

 For installation and/or transport of the microscope or the stand, exclusively use the handle (Fig. 3/5) provided to this effect.

- Remove transport securing devices (adhesive tapes etc.).
- Keep original packaging for a possibly extended period of storage or return of the device to the manufacturer or dispose of it appropriately.

3.2 Installing the stereo microscope

- Place stand (Fig. 7/3) on a level, firm support.
- If the Stemi 508 body (Fig. 7/2) has not yet been mounted, insert it in the Stemi mount (Fig. 7/4), align it and secure it using the clamping screw (Fig. 7/5).
The appropriate Allen key (Fig. 7/8) is located in the support on the back of the device.
- If the two eyepieces (Fig. 7/1) have not yet been mounted, insert them both to their stop in the eyepiece tube.
- Remove the two caps (Fig. 6/1) from the eyepieces.
- Remove the cap (Fig. 6/2) from the specimen by turning it.

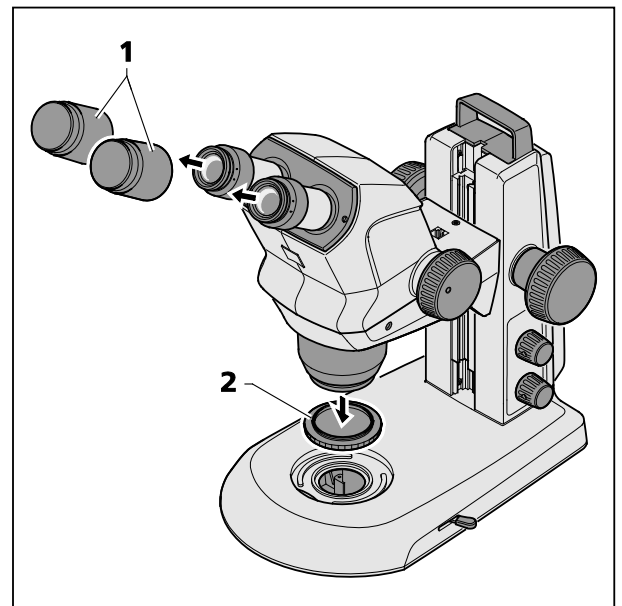

Fig. 6 Removing caps

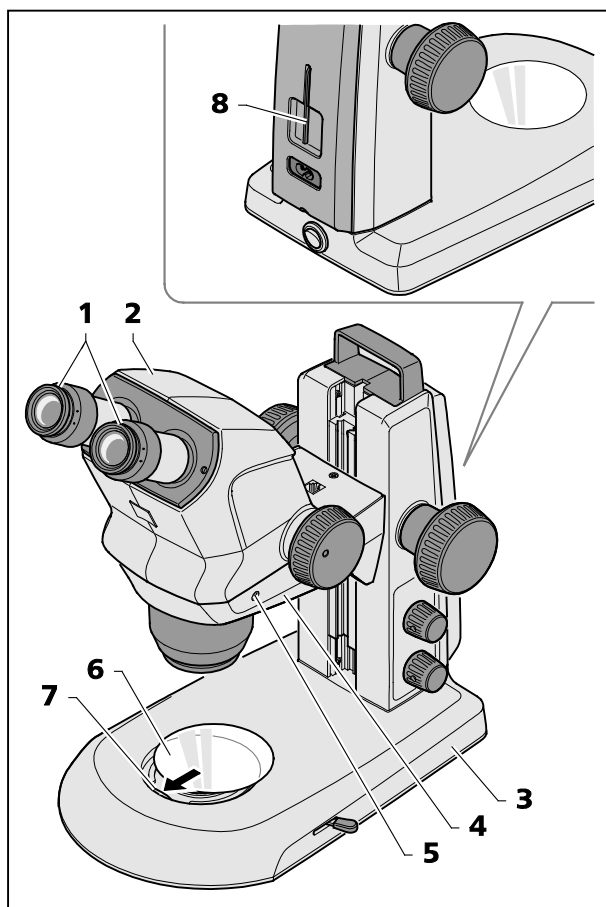

Fig. 7 Installing the stereo microscope

- Insert glass plate or B/W plastic plate (Fig. 7/6) in the mount in the base of the stand. To this effect, press the glass plate or the B/W plastic plate against the spring (Fig. 7/7) and make it lock in.



Installation of a reflected-light illuminator has been described in Section 3.3.1 on page 25.

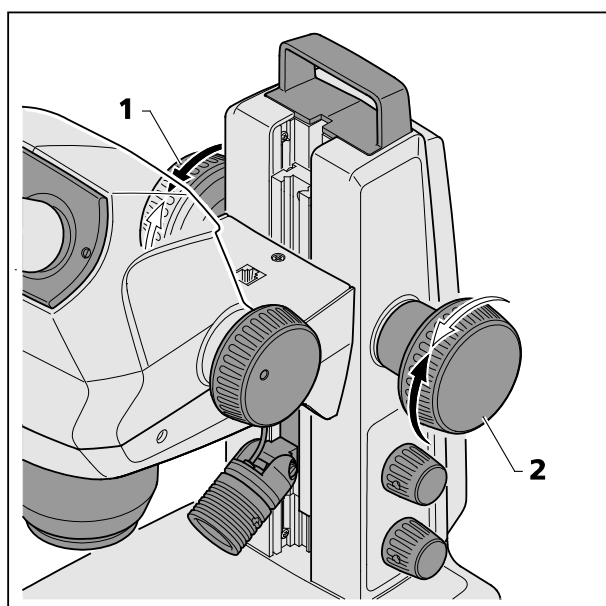

Fig. 8 Setting the ease of motion of the focusing drive



If necessary, the ease of motion of the focusing drive can be set as required on a case-by-case basis by adjusting the two focusing knobs (Fig. 8/1 and 2) in opposite directions.



The ease of motion must not be set so loosely that the drive moves downwards by itself. This might damage the microscope or the specimen.

3.3 Mounting optional components

3.3.1 Mounting reflected-light illuminator

Various reflected-light illuminators can be used, depending on the case of application.

For fastening, defined interfaces have been provided on the microscope.

3.3.1.1 Mounting spot illuminator K LED or double spot illuminator K LED

- Move the microscope body (Fig. 9/1) into its uppermost position via the focusing knob (Fig. 9/2).
- Insert the spot illuminator (Fig. 9/7) in the stand by sliding the holder (Fig. 9/5) into the stand guide (Fig. 9/4) from below and push it upwards into the required position.
- Plug the connection cable (Fig. 9/6) of the spot illuminator into the lower socket of the Stemi mount (Fig. 9/3).

 The double spot illuminator is mounted in an analogical manner.

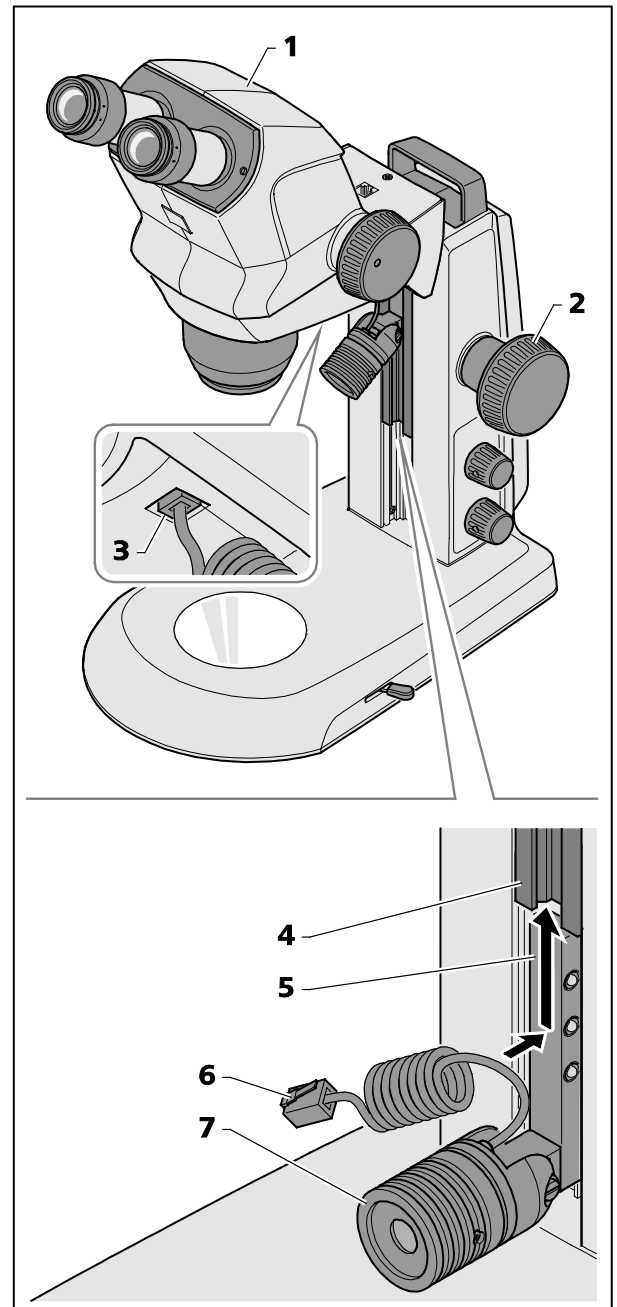

Fig. 9 Mounting spot illuminator

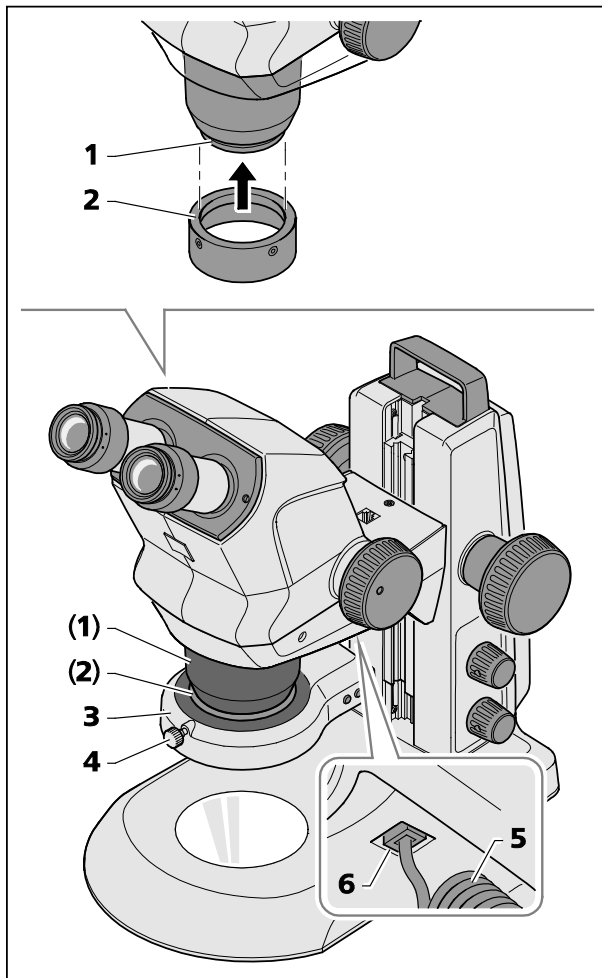

Fig. 10 Mounting ring illuminator

3.3.1.2 Mounting ring illuminator K LED (segmentable)

- Push holding ring A53 (Fig. 10/2) from the underside onto the dust protection glass (Fig. 10/1) of the Stemi 508 and secure it by tightening the two retainer screws (hexagon socket, SW 3).
- Insert the connection cable (Fig. 10/5) of the ring illuminator (Fig. 10/3) into the lower socket (Fig. 10/6) of the Stemi mount and into the socket of the ring illuminator.
- Push ring illuminator onto the retainer ring A53 (Fig. 10/2) from below and secure using the knurled screw (Fig. 10/4).

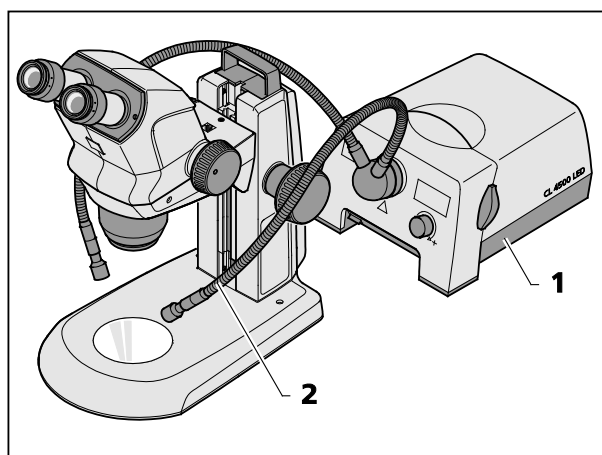

Fig. 11 Mounting external fiber-optic illumination

3.3.1.3 External fiber-optic illumination

- Switch on external fiber-optic illumination (Fig. 11/1), adjust illumination intensity and set illumination by bending the two goose necks (Fig. 11/2) so that the specimen is optimally lit.



To this effect, refer also to the separate operating instructions regarding the cold light source.

3.3.1.4 Placing reversible eyepiece cup onto the eyepiece

The eyepieces feature rubber protection rings for spectacles to avoid the spectacles being scratched. These rings may be replaced at choice by reversible eye cups (Fig. 12/1).

- To this effect remove the protection rings for spectacles (Fig. 12/2) from the eyepieces and position the eye cups (Fig. 12/1).

3.3.1.5 Insert the eyepiece plate into the eyepiece.

The adjustable eyepieces are intended for use with eyepiece plates.

- Unscrew stop (Fig. 12/6) from the eyepiece (Fig. 12/3).
- Pull locking ring (Fig. 12/5) out.
- Insert eyepiece plate (Fig. 12/4).
- Insert locking ring and re-fasten stop.

 If eyepiece plates are inserted by the customer, it must be ensured that the writing is mirror-inverted before insertion into the eyepiece, and true to side after insertion.

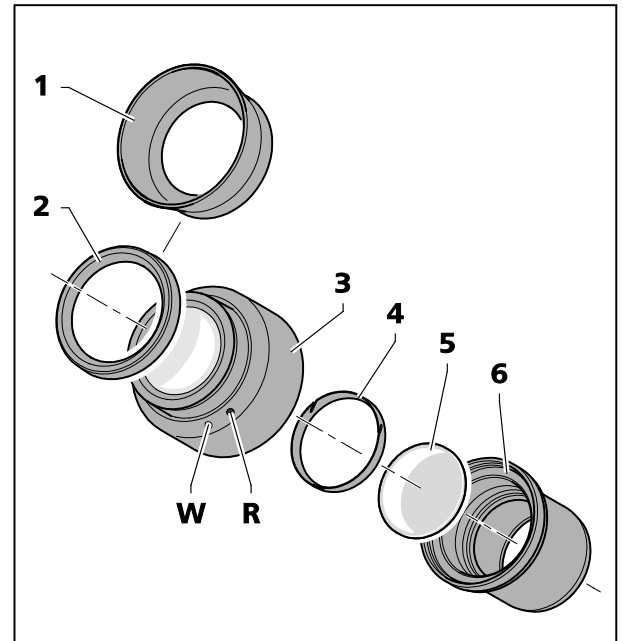

Fig. 12 Inserting the eyepiece plate

 Fine cotton gloves should be worn to insert or replace eyepiece plates.

The slight image offset which is due to the additional glass distance is taken into account on the diopter scale by the zero position not being indicated by the white dot (Fig. 12/W), but by a red dot (Fig. 12/R).

 Eyepieces with pre-inserted eyepiece plates are available directly from ZEISS.

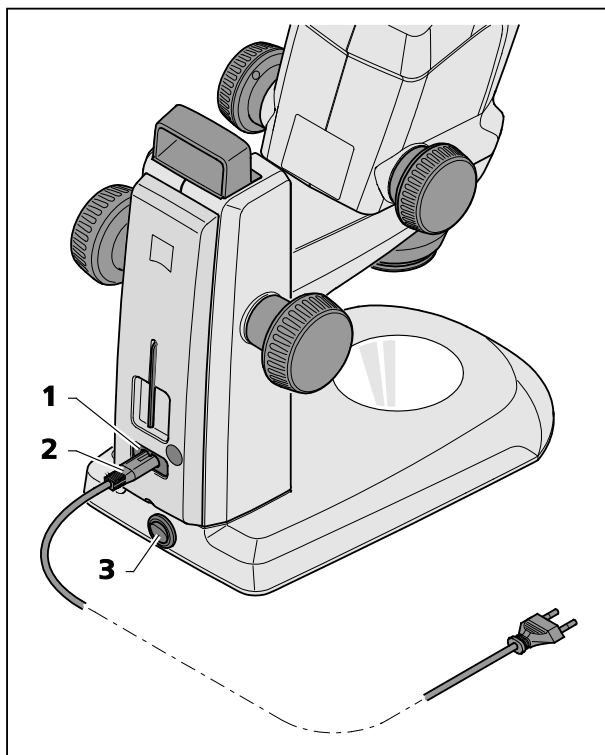

Fig. 13 Connecting the stereo microscope

3.4 Connecting stereo microscope to the power supply

- Insert the mains cable (Fig. 13/2) in the mains supply socket (Fig. 13/1) of the stand.
- Connect the mains cable (Fig. 13/2) to a mains supply socket outlet.

3.5 Switching stereo microscope ON or OFF

- Use the power switch (Fig. 13/3) to switch the stereo microscope ON or OFF.



Safe disconnection from the power supply is ensured exclusively by removing the mains plug. The switch on the stereo microscope only switches into standby mode.



Do not replace detachable mains cables by inadequately designed mains cables. Only the specified power supply lines may be used.

4 OPERATION

4.1 Adjusting the stereo microscope

The stereo microscope has been connected and switched ON.

1. Place specimen (Fig. 14/7) centrally on the glass or plastic plate (Fig. 14/6) and illuminate it (Fig. 14/5).

 The functionality of the knob for the reflected-light illuminator has been described in Section 4.2 on page 30.

2. Set diopter compensation on the adjustable eyepieces (Fig. 14/1) to "0".

 "0" on white dot (without eyepiece plate). "0" on red dot (with eyepiece plate), see Fig. 15.

 Check that the eyepieces are inserted into the tube to their stop.

3. Set individual eye distance by shifting the eyepiece tube laterally (Fig. 14/2), until only **one** complete light circle (specimen field) is visible when looking into the eyepieces with both eyes.

 To this effect, a distance of approx. 2 cm must be maintained between the eye and the eyepiece.

4. Initially, set the zoom (Fig. 14/3) to the smallest magnification.

5. Focus on a small distinct detail in the center of the specimen (Fig. 14/4).

6. Adjust maximum zoom value (Fig. 14/3). Magnification will probably make the distinct detail appear blurred and no longer in the image center.

7. Sharpen the specimen by focusing, then shift the specimen to re-search for the detail and focus "sharply" again (Fig. 14/4).

8. Afterwards, reset to the lowest zoom value and correct any image blurring for each eye separately by diopter compensation **on the adjustable eyepieces** (not on the focusing knob, Fig. 14/4) (compensation of visual defect).

Once the stereo microscope has been adjusted in this way, the image focus remains unchanged over the entire zoom range. This can be verified by increasing or reducing the zoom value.

 After change of the observer, repeat steps **3.** to **8.**

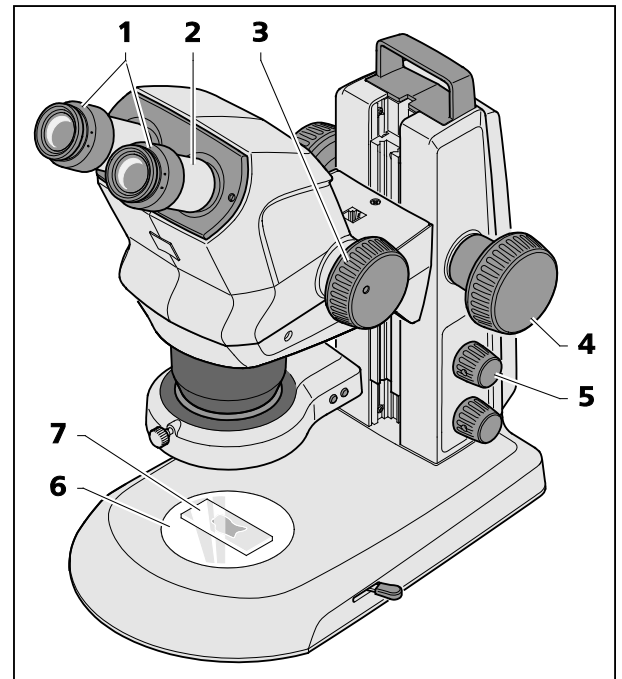

Fig. 14 Adjusting the stereo microscope

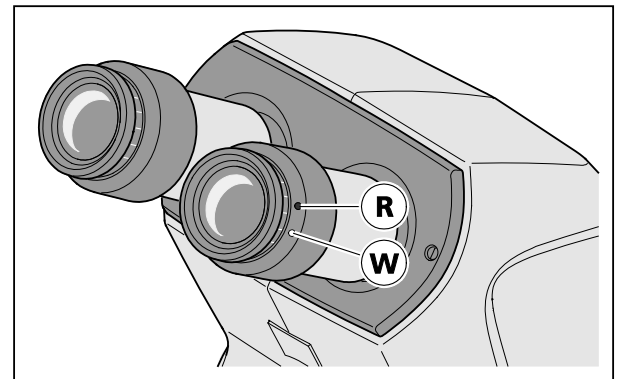

Fig. 15 Adjusting the eyepieces

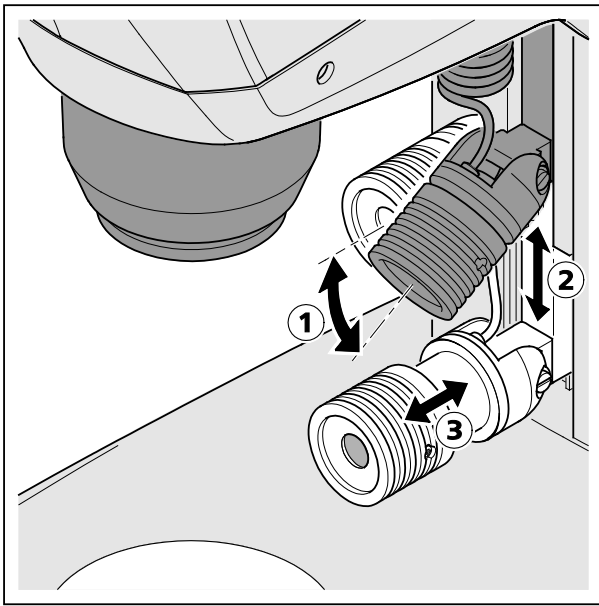

Fig. 16 Setting the spot illuminator

4.2 Setting reflected-light illumination

- By pressing the knob ((Fig. 14/5), the reflected-light illumination is switched ON or OFF (spot illuminator or double spot illuminator).
- By turning the knob, the illumination intensity of the switched-ON reflected light illumination can be adjusted.

4.2.1 Spot illuminator

- Push spot illuminator in the guide to the required height (Fig. 16/2).



In the lower positions, an oblique light effect is created to produce cast shadows for enhancing surface structures.

- Set the angle (Fig. 16/1) via the pivot of the spot illuminator so that the object is optimally illuminated.
- Set size and brightness of the spot by axially shifting the focusing unit (Fig. 16/3) (illumination zoom).

4.2.2 Double spot illuminator

- Move the microscope body to its uppermost position via the focusing knob (Fig. 17/1).
- Push double spot illuminator (Fig. 17/2) to the required level within the guide.
- Bend the two goose necks (Fig. 17/3) to adjust the spots so that the specimen is optimally illuminated.



Here again, an oblique light effect can be produced in the lower positions with the goose neck set horizontally.

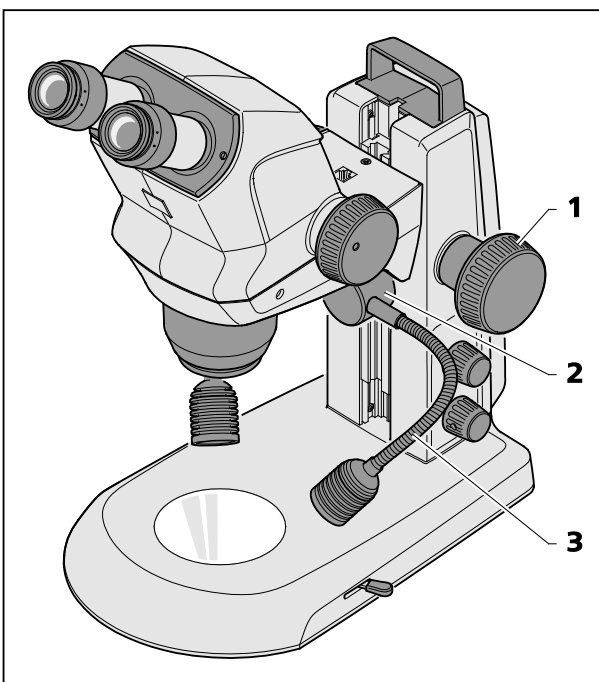

Fig. 17 Double spot illuminator

4.2.3 Ring illuminator

- By pressing the front button (Fig. 18/2) successively, the user can change over between four illumination states of the ring illuminator (Fig. 18/3):
 1. Press: full circle
 2. Press: semi-circle
 3. Press: quadrant
 4. Press: two quadrants (opposite each other)
- When switching the semi-circle or quadrant illumination ON, the specimen is first illuminated from the rear (from the direction of the stand column).
- By pressing the rear button once briefly (Fig. 18/1), the adjusted segment is turned forward clockwise by one quarter turn in each case.
- By pressing and keeping the rear button (Fig. 18/1) pressed for over 2 seconds, the adjusted segment is set into continuous rotation (rotation steps of 1/8 circle, 1 second per turn in each case).
- By pressing the rear button once more (Fig. 18/1), rotation is stopped and the specimen is backlit again.

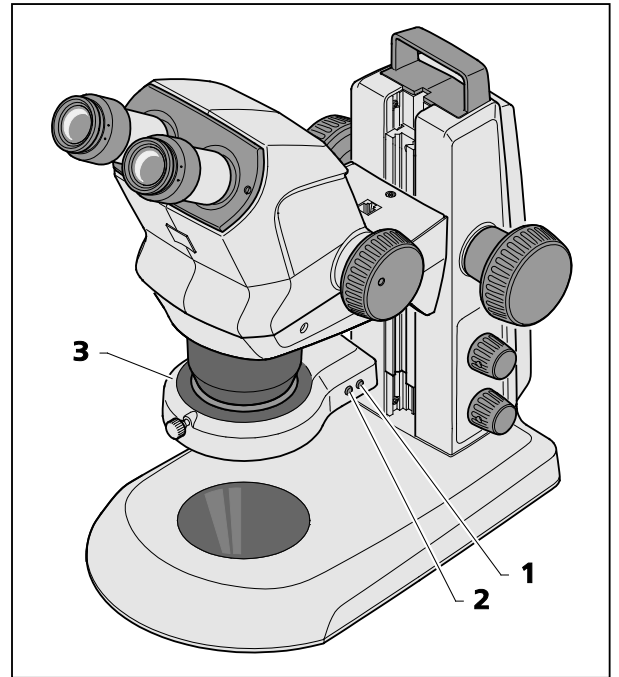

Fig. 18 Ring illuminator



For switching the illumination intensity ON and OFF and adjusting the illumination intensity refer to Section 4.2, page 30.

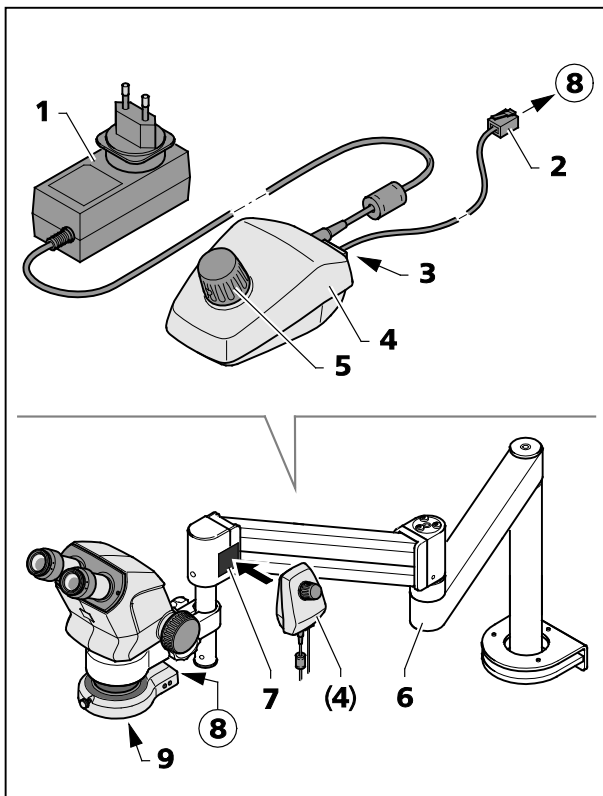

Fig. 19 Controller K LED

4.2.4 Controller K LED

The Controller K (Fig. 19/4) is used to activate the ring illuminator in case of applications with boom stands A or U or additional stands.

- Mount the stands A and U including the fastening of the Stemi 508 body to the Stemi mount as described in the operating instructions for the boom stands.
- Screw-fasten the front lens system (Fig. 19/7) to the microscope body.
- Clamp ring illuminator to the front lens system.



Before using the front lens systems 0.3x or 0.4x, fasten the retainer ring A53 mounting the ring illuminator to the front lens system.

- Secure the adhesive side of the magnetic plate (Fig. 19/7) to the swivel arm stand.
- Plug the connection cable supplied with the device (1 m long) (Fig. 19/2) into the socket (Fig. 19/8) on the ring illuminator and into the socket (Fig. 19/3) on the back of the controller K.
- Place controller K (Fig. 19/4) next to the magnetic plate (Fig. 19/7).

- Connect controller K to the power supply using the power unit (Fig. 19/1).
- Align swivel arm stand (Fig. 19/6) to enable an ergonomic working position.
- Turn the knob (Fig. 19/5) on the controller K to switch the ring illuminator ON and adjust illumination intensity by turning the knob.
- Place specimen in the illuminated specimen field.
- Set the stereo microscope to its initial setting, see Section 4.1 on page 29.

4.3 Transmitted-light illuminators

4.3.1 Transmitted-light module in stand K EDU

- Switch transmitted-light illumination ON by pressing the lower knob (Fig. 20/2).
- With the transmitted light ON, turn this knob to adjust the illumination intensity.
- Change over by adjusting the lever (Fig. 20/3) between the bright field and the dark field illumination.
 - Front position: Dark field (DF)
 - Rear position: Bright field (BF)



Press the upper button (Fig. 20/1) to blend in reflected light (see Section 4.2 on page 30).

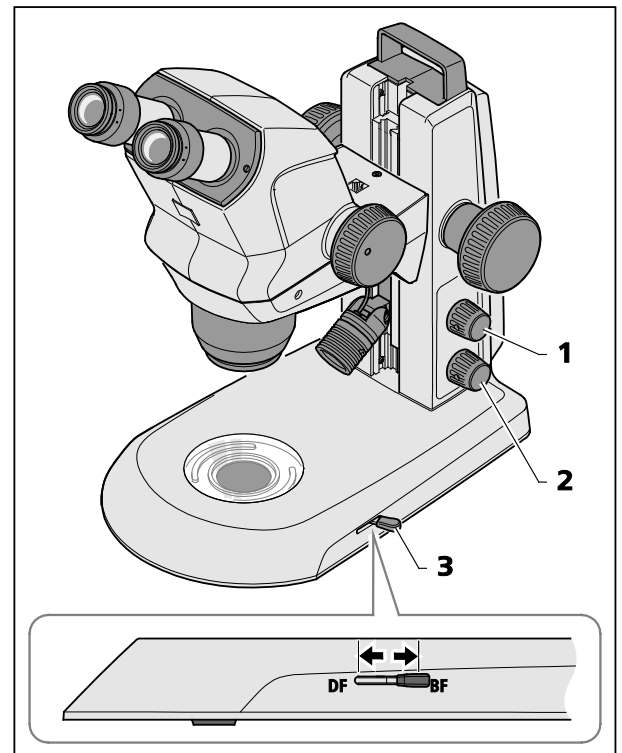

Fig. 20 Transmitted-light module in stand K EDU

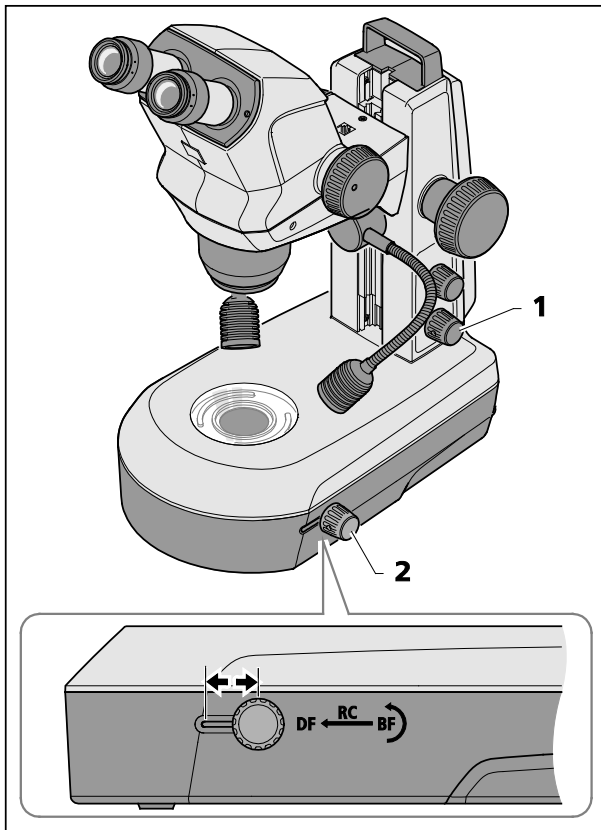

Fig. 21 Transmitted-light unit in stand K LAB

4.3.2 Transmitted-light unit in stand K LAB

- Switch transmitted-light illumination ON by pressing the lower knob (Fig. 21/1).
 - With the transmitted light ON, turn this knob to adjust the illumination intensity.
 - Adjust the bright field (BF) by pushing the sliding knob (Fig. 21/2) into its rear position (BF).
 - Turn the rotary knob / slider (Fig. 21/2) to swing the clear or diffuse mirror in position or to adjust the inclination angle.
- ☞ Clear mirror for high-contrast bright field, diffuse mirror for homogenous bright field.
- Change over to dark field illumination (DF) by pushing the rotary knob / slider (Fig. 21/2) into its front position.
 - Turn the mirror until the specimen structures are brightly lit against the dark background.
- ☞ Oblique light effects (RC) are produced by pushing the rotary knob / slider (Fig. 21/2) into its central position and by tilting the mirror.

5 CARE, MAINTENANCE AND SERVICE

5.1 Care

Care of the devices is restricted to the following operations:



The devices are not equipped with special equipment protecting them from corrosive, potentially infectious, toxic and radioactive or other samples that may be hazardous to health. If you handle such samples, be sure to observe all legal requirements, in particular the relevant national accident prevention regulations.



- Remove contamination in accordance with the national accident prevention regulations.
- Disconnect the devices from the mains power after use. Protect the devices from dust and moisture by using a suitable cover (protective device cover).
- Never expose the devices to inadmissible climate conditions (high humidity and temperature).



Disconnect the devices from the mains power before cleaning. Make sure, that no cleaning fluids penetrate into the device.

Tenacious impurities on glass surfaces such as fingerprints and traces of grease, are best removed using a cotton wool bud wound around a round wooden stick and very little distilled water or non-aggressive solvent:

- Distilled water: Clean glass surface with the slightly moistened cotton wool bud from the center to the edge, using circular movements.
- Cleaning solution for optics, consisting of 15 % isopropanol and 85 % surgical spirit (gasoline): Clean glass surface by the slightly moistened cotton wool bud from the center to the edge, using circular movements.
- Remove dust from optical surfaces using a natural hair brush or blow using rubber bellows (air blower).
- Clean plastic parts using commercially available cleaning products (no solvents!). Tenacious impurities can be treated carefully with benzine or white spirit.
- All labels on the components and on the desktop power unit may only be cleaned using a dry cotton cloth.

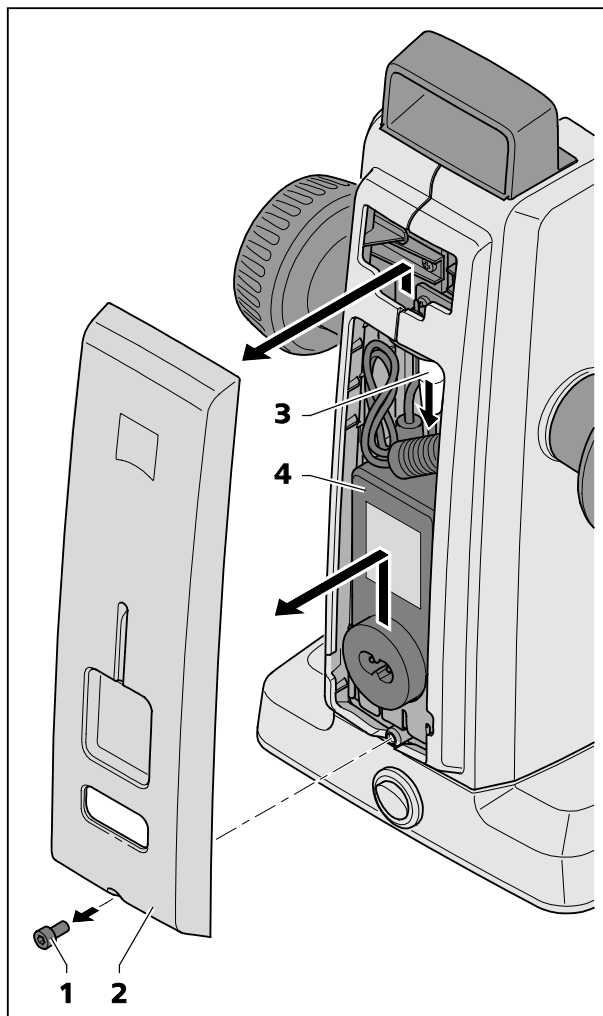

Fig. 22 Changing the power unit

5.2 Maintenance

5.2.1 Replacing the power unit



Only the desktop power unit specified by the manufacturer may be used.



Make sure that the mains plug is removed from the socket before the device is opened.

- Remove the mains plug of the power cable from the socket.
- Remove the power cable from the back of the device.
- Use an Allen key to release the screw (Fig. 22/1) on the underside of the housing cover.
- Pull off housing cover (Fig. 22/2) slightly at the bottom, then press it upwards.
- Release the plug (Fig. 22/3) and remove the faulty desktop power unit (Fig. 22/4).
- Insert the new desktop power unit and connect the plug.
- Press the upper part of the housing cover into place and push housing cover down.
- Secure housing cover by means of the screw.
- Insert the power cable on the back of the device.
- Insert the mains plug into a mains supply socket.

5.2.2 Opening the stand cover plate, stand K EDU

The stand cover plate (Fig. 23/1) may be removed for cleaning or to remove any foreign matter which might have fallen in inadvertently.

- To this effect, release the three recessed head screws (Fig. 23/2), lift off the stand cover plate (Fig. 23/1) carefully and then put it aside.
- Make sure that the cable is not disconnected from the stand cover plate (Fig. 23/1).

 To clean the LED board, use a soft lint-free cloth, a cotton wool bud wound around a round wooden stick or a brush with natural bristles, possibly moistened slightly in distilled water.

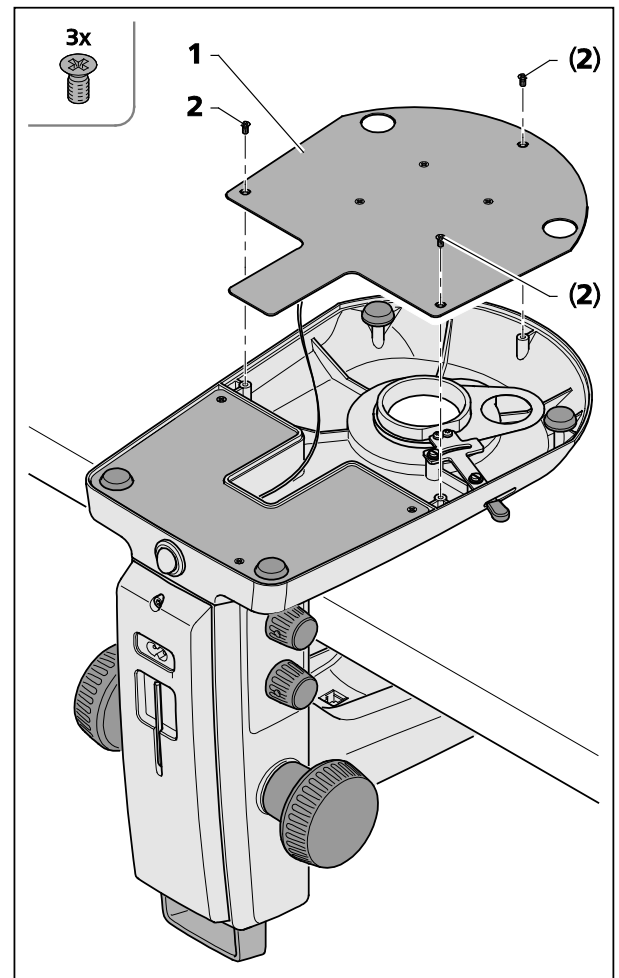

Fig. 23 Opening the stand cover plate,
stand K EDU

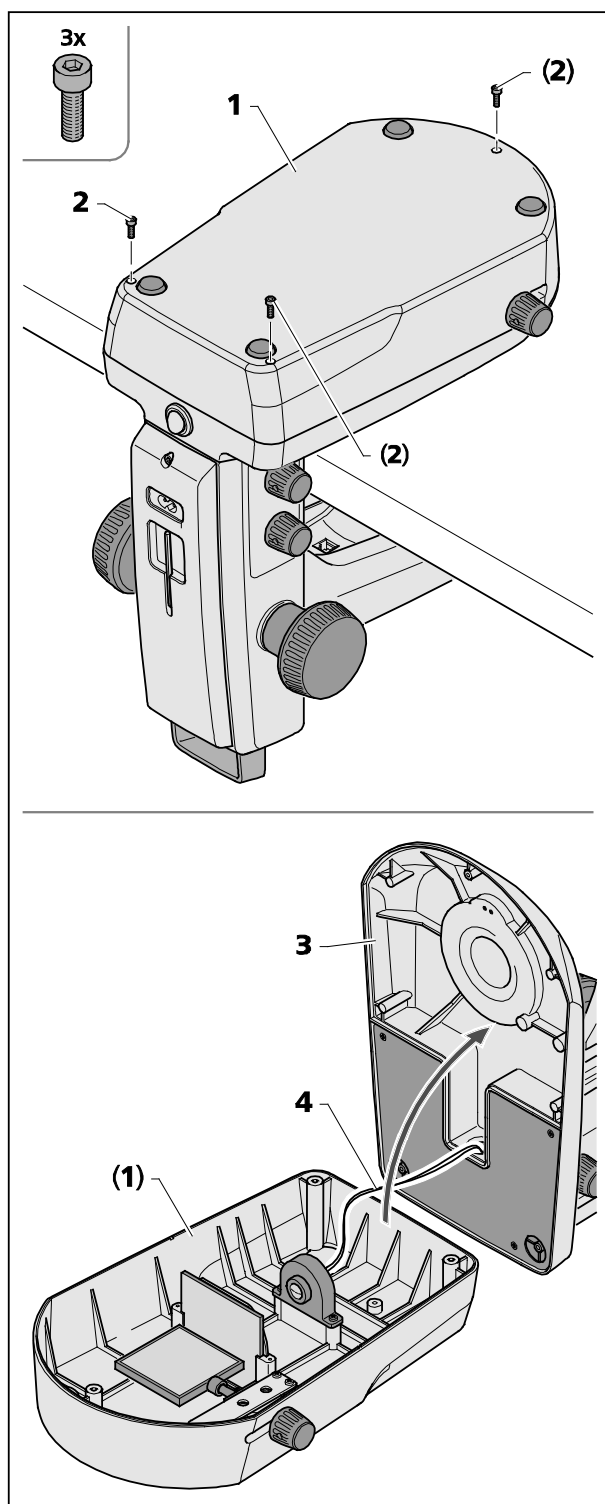

Fig. 24 Opening the stand cover plate,
stand K LAB

5.2.3 Opening the stand cover plate, stand K LAB

The transmitted-light base (Fig. 24/1) can be removed from the stand cover plate (Fig. 24/3) for cleaning or for removal of any foreign matter which might have fallen in inadvertently.

- Release the three screws (Fig. 24/2) from the stand cover plate (Fig. 24/1) using an Allen key SW 2.5 and put them aside.
- Carefully lift the stand cover plate (Fig. 24/3) off the transmitted-light base (Fig. 24/1) and put the stand aside.



Make sure that the cable (Fig. 24/4) is not disconnected from the transmitted-light base (Fig. 24/1).



To clean the LED, the optical elements and the mirror, use a soft lint-free cloth, a cotton wool bud wound around a round wooden stick or a brush with natural bristles, possibly moistened slightly in distilled water.

5.2.4 Wearing parts

The following wearing parts can be ordered directly from ZEISS:

Description	Order No.	Remark
Transparent glass plate, d = 84 mm	435425-9310-000	
SW plastic plate, d = 84 mm	435425-9320-000	
Eyepiece PL 16x/16 Br foc.	444054-9000-000	
Eyepiece cup	444801-0000-000	required 2x
Eyepiece 16x/14 Br foc.	435063-9160-000	
Eyepiece W 25x/10 foc.	455046-9901-000	
Set of small components consisting of: <ul style="list-style-type: none">- 2x spiral cables RJ 12- 1x cable RJ 12, length 1 m- 2x caps, eyepiece- 1x cap, microscope body- 1x Allen key, SW 3- 1x M6 clamping screw, microscope mount- 2x M6 clamping screws for C mount- 2x rubber rings, eyepiece		
Protective dust cover, stand K	415500-1800-000	
Cover, C-mount Stemi 305 trino		

5.3 Service

All interventions in mechanical, optical and electronic internal microscope components may only be performed by Carl Zeiss Service or by specifically **authorized** qualified staff.

To ensure your microscope is optimally set and also operates correctly over an extended period of time, we recommend that you conclude a service/maintenance contract with ZEISS.

For reordering or in case of service, contact your nearest regional ZEISS representative.

5.4 Product disposal

The product was developed, tested and produced in accordance with the valid regulations and guidelines for environmental law of the European Union.

The product and its accessories comply with the EU-regulations 2011/65/EC (RoHS) and 2012/19/EC (WEEE), and the German Electrical and Electronic Equipment Act (ElektroG).

The product contains electronic components which must be disposed of according to the requirements of the 2002/19/EC WEEE Directive and not as domestic waste. In addition, the national regulations must be complied with.

For details on disposal and recycling please refer to your relevant ZEISS sales or service organization.

6 APPENDIX

6.1 List of abbreviations

BF	Bright field
CL	Cold Light
DIN	Deutsche Industrie-Norm (German Industrial Standard)
DF	Dark field
EN	Europäische Norm (European Standard)
IEC	International Electrotechnical Commission
IP	Internal Protection (Type of enclosure)
IVD	In-vitro diagnostics
LED	Light Emitting Diode
RC	Relief contrast (oblique light)
S/W	Schwarz/weiß (black / white)
UV	Ultra-violet

6.2 Troubleshooting

Description of fault	Cause of error	Troubleshooting
Stereo microscope illumination cannot be switched ON.	Power supply interrupted. Power switch not switched ON	Check or establish connection to power supply. Switch power switch on back of stereo microscope ON.
	Power unit faulty.	Replacing the power unit, see Section 5.2.1 on page 36
Vertical reflected-light illumination is not lit.	Power supply cable RJ 12 not plugged in.	Insert RJ plug correctly, see Section 3.2 or 3.3 on pages 23 and 25
Additional reflected-light illuminators are not lit.	Power supply cable RJ 12 not plugged in. Reflected light not switched ON or dimmed.	Insert RJ plug correctly, see Section 3.2 or 3.3 on pages 23 and 25 Press and turn knob Fig. 17/1 several times to switch reflected light ON and to increase its intensity; see Section 4.2 on page 30
Transmitted-light illuminator does not light up	Transmitted light not switched ON or dimmed.	Press and turn rotary / push-button Fig. 20/2 to switch illumination ON and to increase its intensity; see Section 4.3 on page 33
	Transmitted light not connected.	Open stand K EDU or K LAB and according to Section 5.2.2 and 5.2.3 on pages 37 and 38 Connect the plug-in connectors of the LED illumination.
Transmitted-light illuminator dirty or control lever cannot be actuated.	Liquids or foreign matter in the transmitted-light unit.	Open and clean stand K EDU or K LAB and/or eliminate foreign matter according to Section 5.2.2 and 5.2.3 on page 37 and 38
Microscope mount moves down by itself.	Focusing drive too easy to move.	Set ease of motion of the focusing drive, see Section 3.2 on page 23

Should any other faults occur or should you have queries regarding troubleshooting, please contact your regional ZEISS representative.

6.3 List of illustrations

Fig. 1	Warning and information labels on the device.....	10
Fig. 2	Apertures for LED radiation.....	11
Fig. 3	Microscope system Stemi 508.....	12
Fig. 4	Interfaces on the Stemi 508 with stand K (schematic diagram).....	13
Fig. 5	Front optics, Stemi 508 (example).....	13
Fig. 6	Removing caps.....	23
Fig. 7	Installing the stereo microscope.....	24
Fig. 8	Setting the ease of motion of the focusing drive.....	24
Fig. 9	Mounting spot illuminator.....	25
Fig. 10	Mounting ring illuminator.....	26
Fig. 11	Mounting external fiber-optic illumination.....	26
Fig. 12	Inserting the eyepiece plate.....	27
Fig. 13	Connecting the stereo microscope.....	28
Fig. 14	Adjusting the stereo microscope.....	29
Fig. 15	Adjusting the eyepieces.....	29
Fig. 16	Setting the spot illuminator.....	30
Fig. 17	Double spot illuminator.....	30
Fig. 18	Ring illuminator.....	31
Fig. 19	Controller K LED.....	32
Fig. 20	Transmitted-light module in stand K EDU.....	33
Fig. 21	Transmitted-light unit in stand K LAB.....	34
Fig. 22	Changing the power unit.....	36
Fig. 23	Opening the stand cover plate, stand K EDU.....	37
Fig. 24	Opening the stand cover plate, stand K LAB.....	38

6.4 Index**A**

Adjusting the stereo microscope	29
Ambient Conditions	21
Ambient temperature	21
Apertures for LED radiation	11

B

Bright field	33
--------------------	----

C

Care	35
Compensation of visual defect	29
Connecting	28
Contents	5
Controller K LED	32
Copyright	4

D

Dark field	33
Description	12
Dimensions	20
Diopter compensation	29
Double spot illuminator	25

E

Ease of motion of the focusing drive	24
Eyepiece	29
Eyepiece cup	27
Eyepiece plate	27

F

Fiber-optic illumination	26
--------------------------------	----

I

Illumination intensity	31
Illumination state of the ring illuminator	31
Index	44
Indication for use	12
Information labels	10
Information, general	7, 23
Installation	23
Instrument safety	8
Interfaces	13
Introduction	7

L

LED class	8
-----------------	---

M

Maintenance	36
Microscope system	12

O

Operation	29
-----------------	----

P

Product disposal	40
Protection ring for spectacles	27

R

Reflected-light illumination	25
Ring illuminator	26

S

Safety	8
Service	39
Setting	
Reflected-light illumination	30
Stereo microscope	29
Transmitted-light illumination	33
Setting reflected-light illumination	30
Setting transmitted-light illumination	33
Spot illuminator	25
Switching OFF	28
Switching ON	28
Swivel arm stand	32
System overview	14

T

Technical data	20
Transmitted-light module in stand K EDU	33
Transmitted-light unit in stand K LAB	34
Troubleshooting	42

U

Use	12
-----------	----

W

Warning labels	10
Warranty notes	11
Wearing parts	39
Weight	20